

WELLS Counter Point

Volume 3 Issue 2, April 1999

THE ELECTRONIC, DIAGNOSTIC AND DRIVEABILITY RESOURCE.

Getting The Flow Of MAF Sensors

Mass Air Flow (MAF) sensors are used on some General Motors, Ford and import multiport fuel-injected engines to measure the volume of air entering the engine.

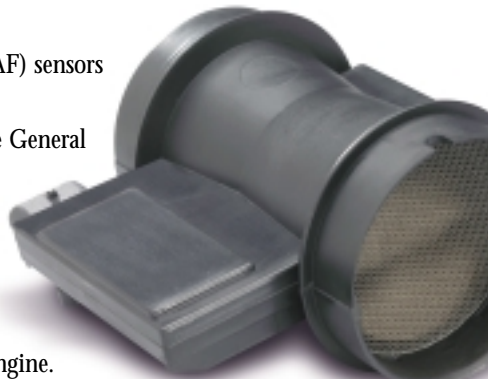

This is necessary for the engine's computer to calculate and maintain the proper air/fuel ratio for optimum performance and emissions. Other engines with "speed-density" fuel injection systems do not have a MAF sensor and use inputs from the throttle position sensor (TPS), manifold absolute pressure (MAP) sensor, incoming air temperature (IAT) sensor and engine rpm to estimate air flow.

The MAF sensor is located in the air duct between the air cleaner and throttle body. Here, it can measure all the air that is being drawn into the engine and react almost instantly to changes in throttle position and engine load.

WIRE & FILM

There are two basic varieties of MAF sensors: hot-wire and hot-film. Unlike vane air flow (VAF) sensors that have a mechanical spring-loaded flap to measure air flow, MAF sensors have no

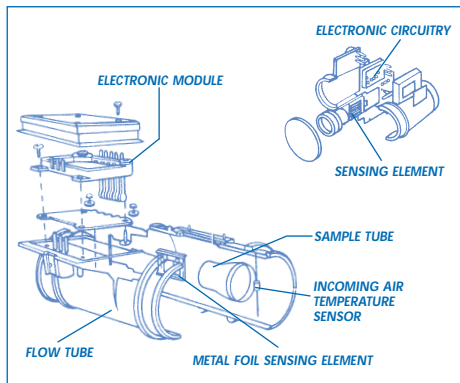

moving parts. Instead, they use a heated sensing element to measure air flow.

In a hot-wire MAF, a platinum wire is heated 212 degrees F above the incoming air temperature. In a hot-film MAF, a foil grid is heated 167 degrees F above ambient air temperature. As air flows past the sensing element, it has a cooling effect. This increases the current needed to keep the sensing element at a constant temperature. The cooling effect varies directly with the temperature, density

and humidity of the incoming air, so the current change is proportional to the air "mass" entering the engine.

The output signal produced by the MAF sensor varies according to the application. The hot-wire Bosch MAF sensors, which are found on some import cars with LH-Jetronic fuel injection dating back to 1979 as well as 1985-89 GM 5.0L and 5.7L Tuned Port Injection (TPI) engines, generate an analog voltage signal that varies from 0 to 5 volts. Output at idle is usually 0.4 to 0.8 volts increasing up to 4.5 to 5.0 volts at wide-open throttle.

The hot-film MAFs, which AC Rochester introduced in 1984 on the Buick turbo 3.8L V6 and were also used on Chevrolet 2.8L engines and GM 3.0L and 3.8L V6 engines, produce a square-wave variable frequency output. The frequency range varies from 32 to 150 Hz, with 32 Hz being average for idle and 150 Hz for wide-open throttle. In 1990, GM switched most of its engines back to speed-density fuel injection systems, except for the Buick 3.3L and 3.8L which changed to a Hitachi MAF sensor.

Another difference between the hot-wire and hot-film sensors is that the Bosch hot-wire units have a self-cleaning cycle where the platinum wire is heated to 1,000 degrees C (1,832 F) for one second after the engine is shut down. The momentary surge in current is controlled by the onboard computer through a relay to burn off contaminants that might otherwise foul the wire and interfere with the sensor's ability to read incoming air mass accurately.

DIAGNOSIS

An engine with a bad MAF sensor may be hard to start or stall after starting. It may hesitate under load, surge, idle rough or run

continued on page 3

Fine Tuning



Fine Tuning questions are answered by Jim Bates, Technical Services Director. Please send your questions to: Jim Bates c/o WELLS Manufacturing Corp., P.O. Box 70, Fond du Lac, WI 54936-0070 or e-mail him at technical@wellsfgcorp.com. We'll send you a WELLS' shirt if your question is published. So please include your shirt size with your question.

Q: "We have a 1989 Chevrolet Caprice 5.7L that has been burning out ignition coils. New plugs and wires didn't help. We even changed the cap and rotor and checked the distributor ground circuit all the way back to the battery negative terminal. The coil still burns out at the primary wire. What else should we be checking?"

Gene's Super Service, Lincoln, IA

There is a grounding strap or wire that connects between one of the ignition coil hold-down screws on the laminations and the center terminal of the three-connector wiring harness. This circuit provides a ground connection to the ignition coil secondary (black) wire, which is connected to another hold-down screw. This grounding wire or strap can be misplaced or discarded during replacement of the ignition coil or distributor cap. In this situation, the ignition coil secondary winding is not grounded and usually arcs a path to ground through the ignition coil primary circuit, causing the failure you described. Be sure to check the current limiter in the ignition control module to be sure it has not been damaged also.

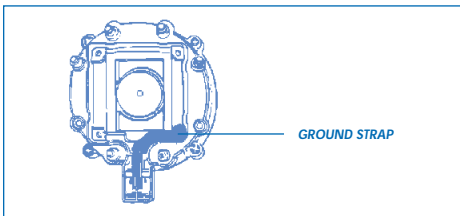

Q: "I have been working on a 1996 Astro van with a 4.5 liter engine. This van has an intermittent stalling problem and at times will not even start. I have checked for proper spark, fuel pressure, reference signal, compression, wiring harness voltages and wiggle test, the works. Any ideas?"

Big John's Service, Fond du Lac, WI

It seems, after some research, that some 1996-98 M/L vans with the 4.5L engine may have been built with the ignition coil wire too close to the transmission fluid fill tube. If so, a condition of grounding out through the wire's insulation and plastic conduit may cause failure of the wire which would lead to the stalling/no start condition you described. Repositioning a new coil wire to provide adequate clearance around fill tubes and metal brackets should do the trick.

Q: "I have been working on a 1997 Saturn SL1, 1.9L SOHC (vin 8) with multipoint fuel injection that has a radio static noise problem that is only present when the car is started in the morning. I can only hear it on the FM stations and it actually decreases as the engine warms up. The noise follows engine RPM, so I have been thinking it is ignition related. But the plugs, wires and coil pack are all OK, and the noise goes completely away after the engine has warmed up. Have you ever heard of this before?"

Grand's Amoco, Twin Falls, IA

This condition may be caused by insufficient retention of the spark plug wire terminal to the spark plug or coil terminal. Remove the plug wires and check for corrosion and/or loose fitting terminals. The corrosion can be removed with a bronze wire brush or equivalent, but do not use solvents or cleaners on these parts. Check the spark plug terminals for evidence of arcing, and the spark plug insulator for evidence of carbon tracking. Replace as necessary. If there is no evidence of arcing or carbon tracking, you can try to tighten up the terminals and reinstall them with a liberal amount of dielectric grease on the coil terminals.

Q: "I have successfully used your WELLS Code Key to retrieve codes on a 1981 Buick Regal in order to help diagnose and fix problems in the past. This time, however, once the key is inserted and the ignition turned on, the check engine light glows with no flashing at all. Does this mean that my engine control module is shot?"

Brian Huntzinger

Maybe not. Your Buick has a device called a "light driver module" that is part of the check engine light circuitry. If there is a short to ground between the check engine light and the light driver module itself, this would cause the type of problem you are having.

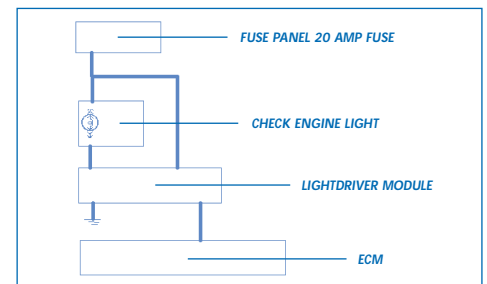

Quality Points

WELLS' MAP Sensors Have QS-9000 Quality

WELLS offers a top-quality line of Manifold Absolute Pressure Sensors for most U.S. and select import applications.

WELLS' MAP sensors feature reliable solid-state design, plus they meet or exceed Original Equipment standards for the parts they replace.

Each WELLS' MAP sensor undergoes rigorous testing. Components are individually tested prior to assembly, and sensors are again tested both

during assembly and after completion to ensure maximum reliability.

Because of this great attention to detail and commitment to quality, WELLS in 1996 became the first full-line manufacturer of ignition components to earn prestigious QS-9000 quality compliance for the design and manufacture of electronic engine management systems, charging systems and sensors.

The Big Three automakers now require that all their Tier 1 suppliers are QS-9000 certified, to ensure the highest quality in new car parts. WELLS also provides top-quality parts to the automotive aftermarket.

"The MAP sensor is an important component affecting driveability," said Gavin Spence, WELLS' vice president of sales and marketing. "Technicians who use WELLS' MAP sensors can be assured they are installing parts of the highest quality."

MAP sensors keep computerized engine control systems informed about engine load, so that the fuel mixture, spark timing and other emission functions can be adjusted as operating conditions change.



Getting The Flow Of MAF Sensors

excessively rich or lean. The engine may also hiccup when the throttle suddenly changes position.

If you suspect a MAF sensor problem, scan for any fault codes. A MAF problem should (but does not always) set a fault code. Codes that may indicate a problem with the sensor include:

GM: Code 33 (too high frequency) and Code 34 (too low frequency) on engines with multiport fuel injection only, and Code 36 on 5.0L and 5.7L engines that use the Bosch hot-wire MAF, if the burn-off cycle after shut-down fails to occur.

Ford: Code 26 (MAF out of range), Code 56 (MAF output too high), Code 66 (MAF output too low), and Code 76 (no MAF change during "goose" test).

Of course, don't overlook the basics, such as low engine compression, low vacuum, low fuel pressure, leaky or dirty injectors, ignition misfire, excessive backpressure (plugged converter), etc., since problems in any of these areas can produce similar driveability symptoms.

TESTING

MAF sensors can be tested either on or off the vehicle in a variety of ways.

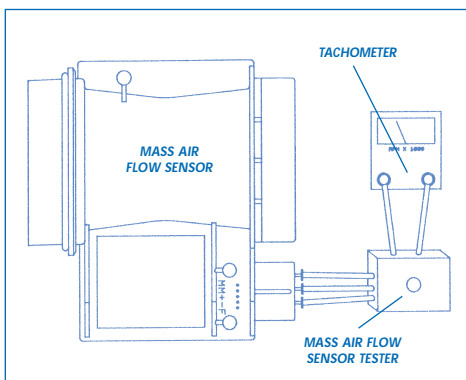

You can use a MAF Sensor Tester and tachometer to check the sensor's response. If testing on the vehicle, unplug the wiring harness connector from the sensor and connect the tester and tachometer. Start the engine and watch the readings. They should change as the throttle is opened and closed. No change would indicate a bad sensor. The same hookup can be used to test the MAF sensor off the vehicle. When you blow through the sensor, the readings should change if the sensor is detecting the change in air flow.

Another check is to read the sensor's voltage or frequency output on the vehicle. With Bosch hot-wire MAF sensors, the output voltage can be read directly with a digital voltmeter by backprobing the brown-and-white output wire to terminal B6 on the PCM. The voltage reading should be around 2.5 volts. If out of range, or if the sensor's voltage output fails to increase when the throttle is opened with the engine running, the sensor may be defective. Check the orange and black feed wire for 12 volts, and the black wire for a good ground. Power to the MAF sensor is provided through a pair of relays (one for power, one for the burn-off cleaning cycle), so check the relays too, if the MAF sensor appears to be dead or sluggish. If the sensor works but is slow to respond to changes in air flow, the problem may be a contaminated sensing element caused by a failure in the self-cleaning circuit or relay.

With GM Delco MAF sensors, attach a digital voltmeter to the appropriate MAF sensor output terminal. With the engine idling, the sensor should output a steady 2.5 volts. Tap lightly on the sensor and note the meter reading. A good sensor should show no change. If the meter reading jumps and/or the engine momentarily misfires, the sensor is bad and needs to be replaced. You can also check for heat-related problems by heating the sensor with a hair dryer and repeating the test.

This same test can also be done using a meter that reads frequency. The older AC Delco MAF sensors (like a 2.8L V6) should show a steady reading of 32 Hz at idle to about 75 Hz at 3,500 rpm. The later model units (like those on a 3800 V6 with the Hitachi MAF sensor) should read about 2.9 kHz at idle and 5.0 kHz at 3,500 rpm. If tapping on the MAF sensor produces a sudden change in the frequency signal, it's time for a new sensor.

On GM hot-film MAFs, you can also use a scan tool to read the sensor's output in "grams per second" (gps), which corresponds to frequency. The reading should go from 4 to 8 gps at idle up to 100 to 240 gps at wide-open throttle.

Like throttle position sensors, there should be smooth linear transition in sensor output as engine speed and load change. If the readings jump all over the place, the computer won't be able to deliver the right air/fuel mixture and driveability and emissions will suffer. So you should also check the sensor's

output at various speeds to see that its output changes appropriately.

Another way to observe the sensor's output is to look at its waveform on an oscilloscope. The waveform should be square and show a gradual increase in frequency as engine speed and load increase. Any skips or sudden jumps or excessive noise in the pattern would tell you the sensor needs to be replaced.

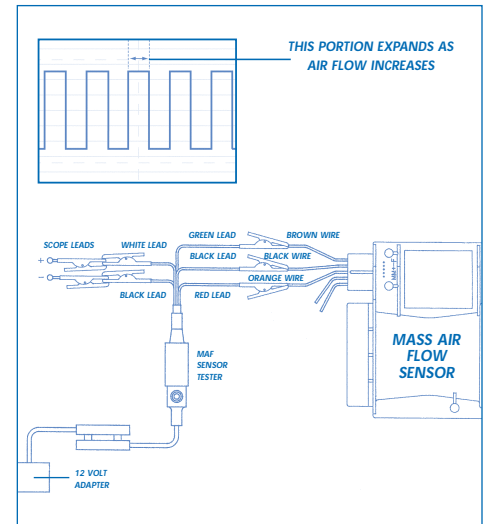

Yet another way to check the MAF sensor is to see what effect it has on injector timing. Using an oscilloscope or multimeter that reads milliseconds, connect the test probe to any injector ground terminal (one injector terminal is the supply voltage and the other is the ground circuit to the computer that controls injector timing). Then look at the duration of the injector pulses at idle (or while cranking the engine if the engine won't start). Injector timing varies depending on the application, but if the mass air flow sensor is not producing a signal, injector timing will be about four times longer than normal (possibly making the fuel mixture too rich to start). You can also use millisecond readings to confirm fuel enrichment when the throttle is opened during acceleration, fuel leaning during light load cruising and injector shut-down during deceleration. Under light load cruise, for example, you should see about 2.5 to 2.8 Ms duration.

(In the next issue of Counter Point, we'll cover vane air flow (VAF) sensors such as those used on some Ford and import vehicles, and Karman-Vortex air flow sensors used by Toyota and Mitsubishi.)

WELLS

WELLS MANUFACTURING CORP.
P.O. Box 70
Fond du Lac, WI 54936-0070

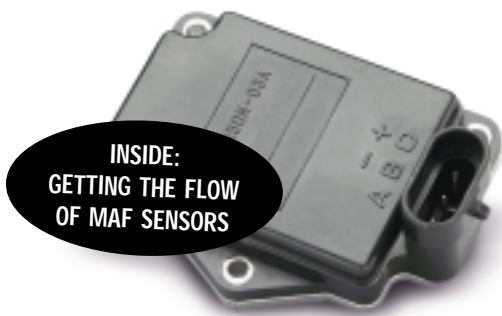

Hot off the Wire

WELLS Offers Thorough And Timely Reference Materials

WELLS offers technicians thorough up-to-date reference materials, including its 1998-1999 catalog and illustrated buyer's guide.

WELLS' Engine Performance Systems catalog contains more than 1,500 pages and the Buyers Guide contains more than 700 pages. Expanded coverage of 1,500 new part numbers includes numerous 1999 model-year applications.



Part numbers listed now exceed 15,000 for components including sensors, actuators, ignition coils, voltage regulators, control modules, distributor caps, spark plug wires and many others.

Other features of the Catalog and Buyer's Guide include:

- 1 The addition of new categories to the Professional Gold premium performance components program, including coils, tune-up kits and starter solenoids
- 2 An updated part number interchange from Original Equipment Manufacturers to WELLS

"At WELLS, we believe in providing the highest quality parts, broad coverage and sensible pricing," said Gavin Spence, WELLS' vice president of sales. "We also believe in providing our customers with thorough, well-organized and timely reference materials."

Technicians can obtain additional information on reference materials by contacting their WELLS representative.



Publisher's Information

WELLS' PresidentWilliam Allen
Vice President SalesGavin Spence
Technical Services DirectorJim Bates
Newsletter EditorRon Raposa

Counter Point is a quarterly publication of WELLS Manufacturing Corp., P.O. Box 70, Fond du Lac, WI 54936-0070. Letters and comments should be directed to: Counter Point Editor, c/o WELLS Manufacturing Corp, P.O. Box 70, Fond du Lac, WI 54936-0070.

© COPYRIGHT 1999 WELLS MANUFACTURING CORP.
All rights reserved. No reproduction in whole or part is permitted without the written consent of WELLS Manufacturing Corp.